

CEILING FAN AIR DELIVERY TESTER

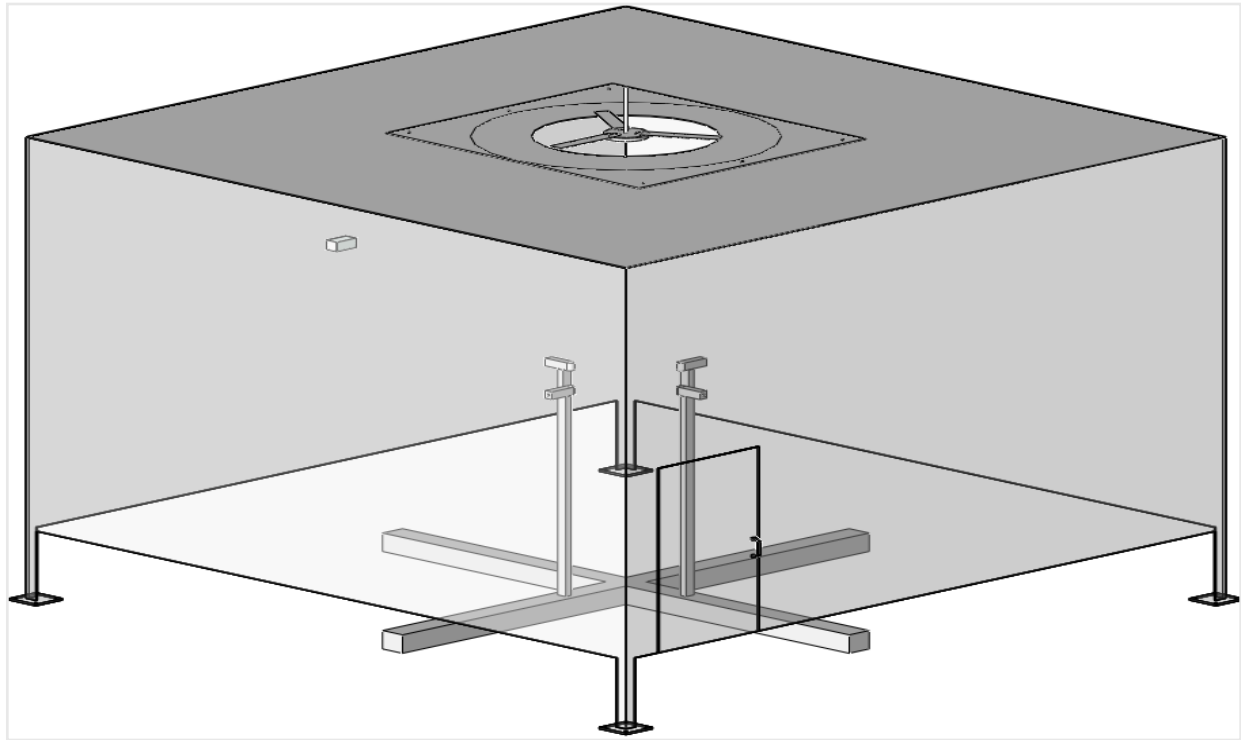

Features:

- Centralized control unit.
- Hassle free fan mounting process.
- Automatic shroud selection.
- Real time RPM monitoring
- Automatic voltage regulator
- Real time environmental monitoring
- Generates test report as per IS374 for every DUT.
- Have a separate interface for equipment maintenance, calibration.
- NABL accredited calibration provided.
- LCD display.
- Inbuilt UPS for control system.

Technical specifications:

General information	
Test chamber dimension	4.50 L x 4.50 W x 3 H
Material	Plywood
Weight	400 Kg
System Power rating	1380 W
Interface	Mini PC with keyboard and mouse, USB port
Air velocity	
Range	0 - 30m/s
Air velocity resolution	0.1m/s
Air velocity Accuracy	±(2%0.1m/s)
Power and Current measurement	
Voltage rating AC	90-300V
Current rating	5A
Frequency rating	50Hz
Power rating	56-85W
Voltage accuracy	±0.5%
Current accuracy	±0.5%
RPM	
Range	300-350
Accuracy	±0.5%
Duration	2 hours
Nominal temperature	15°C and 35°C
Relative humidity	
Range	5 & 99%
Accuracy	±2%
Pressure	
Range	15 to 115kPa
Accuracy	1.5%
Temperature	
Range	-40 and 80 deg c
Accuracy	±0.5 %

Version	Revision date	Pre.By	Rev.By	Apr.By
00	04/04/2024	SK	MB	AKD

Address: 24 Rajunagar-2, Jothipuram Post, Periyanaickenpalayam, Coimbatore, 641047

📧 www.yashika.shop || ✉ sales@yashikaa.in || ☎ +91 4224011111